



USER MANUAL  
EVAPORATOR RS 100 PRO



## **Contenu**

Préface

Service

Warranty

1. Safety Instructions

2. Proper Use

3. Inspection

3.1 Receiving Inspection

3.2 Listing of Items

4. Control and Display

4.1 Control elements

4.2 Display

5. Installation and Operation

5.1 Installation

5.2 Operation

6. Faults

7. Maintenance and Cleaning

8. Associated Standards and Regulations

9. Specifications

## **Preface**

Welcome to the "Rotary Evaporator User Manual". Users should read this Manual carefully, follow the instructions and procedures, and be aware of all the cautions when using this instrument.

## **Service**

When help needed, you can always contact the Service Department for technical support in the following ways:

ROGO-SAMPAIC

23 rue Ampère – ZI de Villemilan

91320 WISSOUS

FRANCE

Tel: +33(0)1 69 53 67 67

Fax: +33(0)1 69 30 72 55

E-mail: [rogosampaic@rogosampaic.com](mailto:rogosampaic@rogosampaic.com)

[Http://www.rogosampaic.com](http://www.rogosampaic.com)

Please provide the customer care representative with the following information :

- Serial number (on the rear panel)
- Certification
- Description of problem (i.e., hardware or software)
- Methods and procedures adopted to resolve the problems
- Your contact information

## **Warranty**

This instrument is warranted to be free from defects in materials and workmanship under normal use and service, for a period of 24 months from the date of invoice. The warranty is extended only to the original purchaser. It shall not apply to any product or parts which have been damaged on account of improper installation, improper connections, misuse, accident or abnormal conditions of operation. For claims under the warranty please contact your local supplier.

### **1. Safety Instructions**

- Read the operating instructions in full before starting up and follow the safety instructions.
- Keep the operating instructions in a place where they can be accessed by everyone.
- Ensure that only trained staff work with the appliance.
- Follow the safety instructions, guidelines, occupational health and safety and accident prevention regulations. When working under a vacuum in particular!
- Wear your personal protective equipment in accordance with the hazard category of the medium to be processed. Otherwise there is a risk of :

- Splashing liquids,
- Body parts, hair, clothing and jewellery getting caught,
- Injury as a result of glass breakage.



**CAUTION!** Inhalation of or contact with media such as poisonous liquids, gases, spray mist, vapours, dusts or biological and microbiological materials can be hazardous to user.

- Set up the device in a spacious area on an even, stable, clean, non-slip, dry and fireproof surface.
- Ensure that there is sufficient space above the device as the glass assembly may exceed the height of the device.
- Prior to each use, always check the device, accessories and especially the glass parts for damage. Do not use damaged components.
- Ensure that the glass assembly is tension-free! Danger of cracking as a result of:
  - Stress due to incorrect assembly,
  - External mechanical hazards,
  - Local temperature peaks.
- Ensure that the stand does not start to move due to vibrations respectively unbalance.
- Beware of hazards due to:
  - Flammable materials,
  - Combustible media with a low boiling temperature,
  - Glass breakage.



**CAUTION!** Only process and heat up media that has a flash point higher than the adjusted safe temperature limit of the heating bath that has been set.

- The safe temperature limit of the heating bath must always be set to at least 25 °C lower than the fire point of the media used.
- Do not operate the appliance in explosive atmospheres, with hazardous substances or under water.
- Only process media that will not react dangerously to the extra energy produced through processing. This also applies to any extra energy produced in other ways, e.g. through light irradiation.
- Tasks with the device must only be performed when operation is monitored.
- Operation with excess pressure is not permitted (for cooling water pressure see "Technical Data").
- Do not cover the ventilation slots of the device in order to ensure adequate cooling of the drive.
- There may be electrostatic discharges between the medium and the drive which could pose a direct danger.
- The appliance is not suitable for manual operation.
- Safe operation is only guaranteed with the accessories described in the "Accessories" chapter.
- Refer to the operating instructions for the accessories, e.g. vacuum pump.
- Only use the device under an all side-closed exhaust, or a comparable protective device.
- Adapt the quantity and the type of distilland to the size of the distillation equipment. The cooler must work properly. Monitor the coolant flow rate at the cooler outlet.
- The glass equipment must always be ventilated when working under normal pressure (e.g. open outlet at cooler) in order to prevent a pressure build-up.
- Please note that dangerous concentrations of gases, vapours or particulate matter can escape through the outlet at the cooler. Take appropriate action to avoid this risk, for example, downstream cold traps, gas wash bottles or an effective extraction system.
- Evacuated glass vessels must not be heated on one side; the evaporating flask must rotate during the heating phase.
- The glassware is designed for operation under a vacuum of up to 10 mbar. The equipment must be evacuated prior to heating (see chapter "Commissioning"). The equipment must only be aired again after cooling. When carrying out vacuum distillation, uncondensed vapours must be condensed out or safely dissipated. If there is a risk that the distillation residue could disintegrate in the presence of oxygen, only inert gas must be admitted for stress relief.



**CAUTION!** Avoid peroxide formation. Organic peroxides can accumulate in distillation and exhaust residues and explode while decomposing!

- Keep liquids that tend to form organic peroxides away from light, in particular from UV rays and check them prior to distillation and exhaust for the presence of peroxides. Any existing peroxides must be eliminated. Many organic compounds are prone to the formation of peroxides e.g. dekalin, diethyl ether, dioxane,

tetrahydrofuran, as well as unsaturated hydrocarbons, such as tetralin, diene, cumene and aldehydes, ketones and solutions of these substances.



**DANGER OF BURNING!** The heating bath, tempering medium, evaporator piston and glass assembly can become hot during operation and remain so for a long time afterwards! Let the components cool off before continuing work with the device.



**ATTENTION!** Avoid delayed boiling! Never heat the evaporating flask in the heating bath without switching on the rotary drive! Sudden foaming or exhaust gases indicate that flask content is beginning to decompose. Switch off heating immediately. Use the lifting mechanism to lift the evaporator piston out of the heating bath. Evacuate the danger zone and warn those in the surrounding area!

- When the device is switched off or the power supply disconnected, the internal safety lift removes the evaporator piston from the heating bath.



**CAUTION!** Never operate the device when the evaporator piston is rotating and the lift is raised. Always lower the evaporator piston into the heating bath first before starting the rotation drive. Otherwise hot tempering medium may be sprayed out!

- Set the speed of the drive so no tempering medium is sprayed out as a result of the evaporator piston rotating in the heating bath. If necessary reduce the speed.
- Do not touch rotating parts during operation.
- Imbalance may result in uncontrolled resonance behaviour of the device or assembly. Glass apparatus may be damaged or destroyed. In the event of unbalance or unusual noises, switch off the appliance immediately or reduce the speed.
- The appliance does not start up again automatically following a cut in the power supply.
- The device is only disconnected from the power supply network if the device power switch is off or the plug is pulled out.
- The socket for the mains cord must be easily accessible.
- The voltage stated on the type plate must correspond to the mains voltage.
- Socket must be earthed (protective ground contact).
- Removable parts must be refitted to the appliance to prevent the infiltration of foreign objects, liquids etc.
- Protect the appliance and accessories from bumps and impacts.
- The appliance may only be opened by experts.

## 2. Proper Use

The instrument is designed for distilling in schools, laboratories or factories. Together with the accessories recommended by manufacturer, the device is suitable for:

- Quick and gentle distillation of liquids
- Evaporation of solutions and suspensions
- Crystallisation, synthesis or cleaning of fine chemicals
- Drying of powder and granulate material
- Recycling of solvents

This device is not suitable for using in residential areas or other constraints mentioned in Chapter 1.

## 3. Inspection

### 3.1 Receiving Inspection

Unpack the equipment carefully and check for any damages which may have arisen during transport. Please contact manufacturer/supplier for technical support.

#### Note:

If there is any apparent damage to the system, please do not plug it into the power line.

### 3.2 Listing of Items

The package includes the following items:

Items	Qty
Main unit	1
Heating bath	1
Power cable	1
Glassware vertical	1
User Manual	1

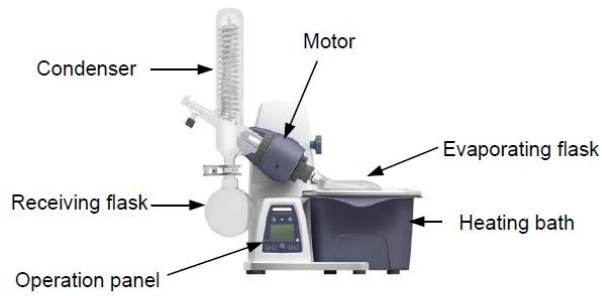

Figure 1

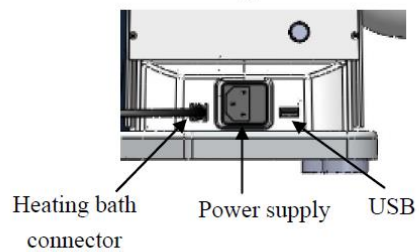

Figure 2

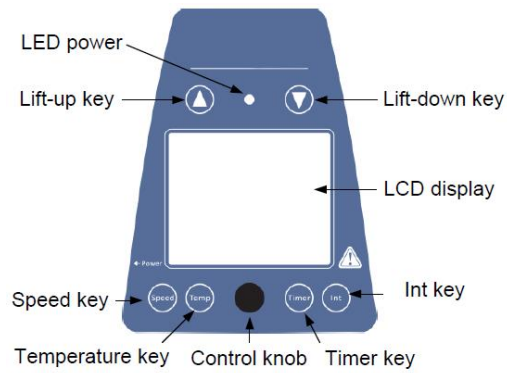

Figure 3



Figure 4

Items	Descriptions
Speed key Speed	Push the key and then rotate control knob to set the rated speed in the range from 20 to 280.
Temperature key Temp	Push the key and then rotate control knob to set the rated temperature in the range from room temperature to 180°C.
Timer key Timer	Push the key and then rotate control knob to set the rated time in the range from 1 to 999min.
Int key Int	Push the key and then rotate control knob to set the interval for right-left running in the range from 1 to 999s.
Control knob	Clockwise rotate to increase program values. Rotate anti-clockwise to decrease program values. Press the knob, switch ON/OFF the unit.
Lift-up key	Press the key, the lift goes up. Release the key the lift stops and remains in that position.
Lift-down key	Press the key, the lift goes down. Release the key the lift stops and remains in that position.
LCD display	LCD displays the real working state.
LED power	Power ON, LED power flash. When the unit running, LED power is lit.
Power switch	Power ON or OFF.

Table 2

#### 4.2 Display

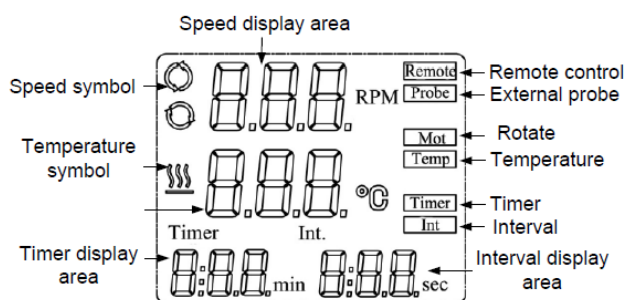

Figure 5

Display	Descriptions
Remote	Display in case of remote control.
Probe	Display when using external probe.
Mot	Display when the rotating function is switched ON.
Temp	Display when the heating function is switched ON.
Timer	Display when timer function is switched ON.
Int	Display when "Int" function is switched ON.
Speed display area	When setting speed, displaying the setting value and flashed. The setting value does not flash until real speed reaches the set point.
Speed symbol	Display when the rotating function is switched ON.
Temperature display area	When setting temperature, displaying the setting value. When the heating function is switched ON, displaying the real value
Temperature symbol	Display when the heating function is switched ON.
Timer display area	When setting timer, displaying the rated time. When the timer function is switched ON, displaying remaining time.
Interval display area	Displaying the "Int" target value.

Table 3

## 5. Installation and Operation

## 5.1 Installation

- Adjustable base (Figure 6).

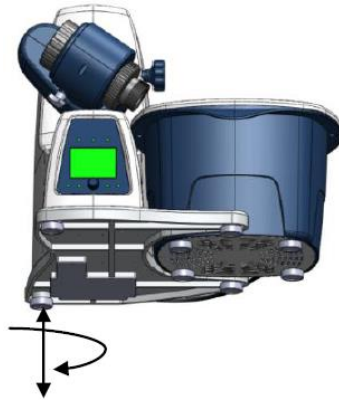

Figure 6



**CAUTION !** Loosen transportation lock (Figure 7).

- Hold the lift with your hand on the height position and remove the thumb screw on the back of the appliance (a).
- Once the transportation lock has been removed, the lift moves slowly to its upper end position. The distance is 150mm.
- Connect the device to the power supply using power cable (b).
- Connect the heating bath to the device (c).

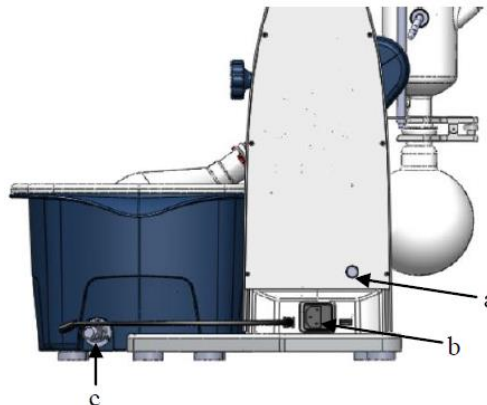

Figure 7

- Remove the clamping device for the angle setting of the rotation drive on the right side of the lift by rotating the knurled screw (d) counter clockwise.
- Set the drive at an angle of approx.30° (Figure 8)
- Then secure the rotation drive from being accidentally turned by tightening the knurled screw in a clockwise direction.

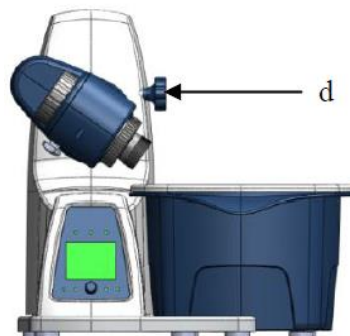

Figure 8

- Open the locking device on the drive head by turning it 60° counter clockwise (e), (Figure 9).

- Feed the steam pipe in until it stops.
- Then lock the locking device by turning it clockwise by 60°.
- The plastic screw nut (f) helps loosen tight-fitting piston ground-in connections (Figure 9).
- Hold the tight-fitting evaporator piston and counter clockwise (e), and then turn the plastic screw nut (f) until the evaporator piston neck.

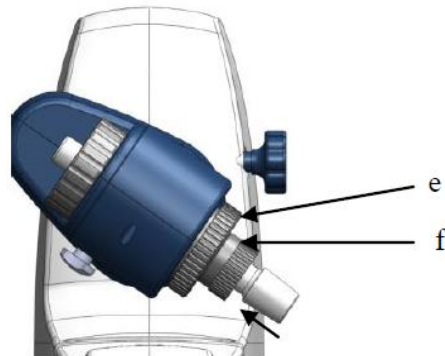

Figure 9

*Note: Prior to commissioning, hand-tighten the plastic screw nut (f) left-aligned.*

Installing condenser seal (Figure 10 and Figure 11).



Figure 10

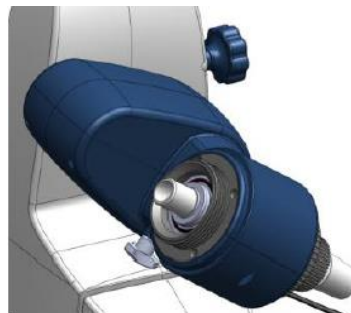

Figure 11

Installing condenser (g) (Figure 12 and Figure 13).

- Load the cap nut (h) and locking spring (i) to condenser in turn.
- Tighten the cap nut hand-screwed (h). Start the device at 200 rpm for 2 min. Then tighten the cap nut firmly.

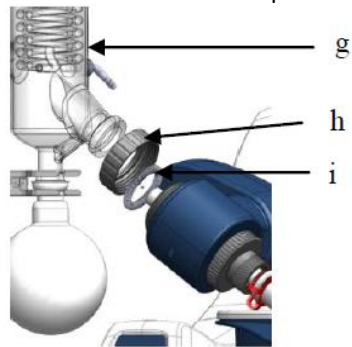

Figure 12

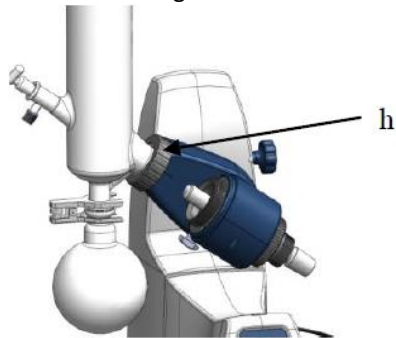

Figure 13

Installing the vertical glassware condenser locking device (Figure 14).

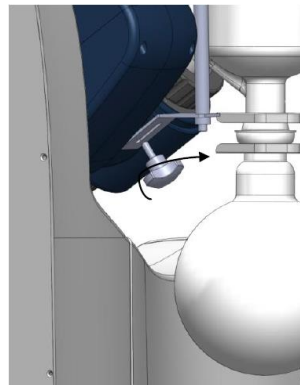

Figure 14

- Connecting tubes (Figure 15).

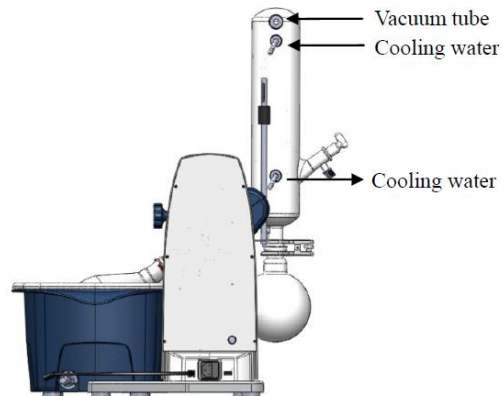

Figure 15

## 5.2 Operation

- Make sure the required operating voltage and power supply voltage match.
- Ensure the socket must be properly grounded.
- Plug in the power cable, ensure the power is on and begin initializing.
- Press Lift-up/Lift-down key, the lift goes up/down.
- Release Lift-up/Lift-down key, the lift stops.
- Push the speed key and then rotate control knob to set the rated speed.
- Push the temperature key and then rotate control knob to set the rated temperature.
- Push the timer key and then rotate control knob to set the rated time.
- Deactivate the timer by setting the target value to "0".
- Press the Int key and then rotate control knob to set the rated interval value.
- Deactivate the interval by setting the target value to "0".
- Press the control knob, switch ON.

If these operations above are normal, the device is ready to operate. If not, the device may be damaged during transportation, please contact manufacturer/supplier for technical support.



CAUTION ! Forbid to transfer the flask when the instrument working.

## 6. Faults

- Instruments can't be power ON
  - Check whether the power line is unplugged
  - Check whether the fuse is broken or loose
- Fault in power on self-test
  - Switch OFF the unit, then switch ON and reset the instruments to factory default setting.

*If these faults are not resolved, please contact manufacturer/supplier.*

## 7. Maintenance and Cleaning

- Proper maintenance can keep instruments working properly and lengthen its lifetime.
- Do not spray cleanser into the instrument when cleaning.
- Unplug the power line when cleaning.
- Only use recommended cleansers:

Dyes	Isopropyl alcohol
Construction materials	Water containing tenside / Isopropyl alcohol
Cosmetics	Water containing tenside / Isopropyl alcohol
Foodstuffs	Water containing tenside
Fuels	Water containing tenside

Before using other method for cleaning or decontamination, the user must ascertain with the manufacturer that this method will not harm the instrument. Wear the proper protective gloves during cleaning of the instrument.

### Note:

- Electronic device cannot clean with cleanser.
- If you require maintenance service, must be cleaned the instrument in advance to avoid pollution of hazardous substances, and to send back into original packing.
- If the instrument will not use for a long time, please switch off and place in a dry, clean, room temperature and stable location.

## 8. Associated Standards and Regulations

Construction in accordance with the following safety standards:

EN 61010-1  
UL 3101-1  
CAN/CSA C22.2(1010-1)  
EN 61010-2-10

Construction in accordance with the following EMC standards:

EN 61326-1  
Associated EU guidelines:  
EMC-guidelines: 89/336/EWG  
Instrument guidelines: 73/023/EWG

Changes or modifications not expressly approved by the party responsible for compliance could void the user's authority to operate the equipment. NOTE: This equipment has been tested and found to comply with the limits for a Class A digital device, pursuant to Part 15 of the FCC Rules. These limits are designed to provide reasonable protection against harmful interference when the equipment is operated in a commercial environment. This equipment generates, uses, and can radiate radio frequency energy and, if not installed and used in accordance with the instruction manual, may cause harmful interference to radio communications. Operation of this equipment in a residential area is likely to cause harmful interference in which case the user will be required to correct the interference at his own expense.

## 9. Specifications

Items	Specifications
Voltage [VAC]	100-240
Frequency [Hz]	50/60
Power [W]	1400
Motor	External rotor brushless motor
Speed Range [rpm]	20-280
Speed Display	LCD
Reversible Direction of Rotation	Yes
Temperature Range [°C]	RT -180
Heat Control Accuracy [°C]	±1
Temperature Display	LCD
Heat Output [W]	1300
Lift	Motor
Stroke [mm]	150
Timer [min]	1-999
Overall Dimensions [D×W×H ,mm]	465×457×583
Weight [kg]	15
Permissible Ambient Temperature [°C]	5 - 40
Permissible Relative Humidity	80%
Protection Class acc. To DIN EN60529	IP20
USB	Yes

Table 4